



## **OLYMPIA™ Battery Edger**

## WARRANTY

### **Welcome to the OLYMPIA™ Advantage**

The entire OLYMPIA™ Product line is designed and built to exacting standard to provide trouble free performance. Like all mechanical equipment however, trouble free performance requires a complete maintenance and proper operating procedures to be followed. Failure to follow a complete and on-going maintenance program will invalidate the Resurface Corp. warranty on the OLYMPIA™ Battery Edger.

Purchaser: .....

Address: .....  
.....  
.....  
.....

Model: .....

Serial Number: .....

Date Delivered: .....

The illustrations and product information contained in this manual were current at the time of publication. In order to continue Resurface Corp.'s development of its technology, Resurface Corp. reserves the right to change designs, models and specifications without notice and without liability for such changes.

Resurface Corp. warrants the components of your OLYMPIA™ Battery Edger against defects in material and workmanship, for two full years from the date of delivery.

The motor for your OLYMPIA™ Battery Edger is a Briggs & Stratton Etek™. To validate it's warranty it must be placed on an ongoing maintenance program as outlined in the motor manual included with the OLYMPIA™ Battery Edger. The charger is a Guest® Smart Charger 2621. For the continued safe, economic operation and to validate the Resurface Corp. warranty, the over all maintenance and operation of your OLYMPIA™ Battery Edger must strictly follow the guideline outlined in this manual.

**Resurface Corp. or an authorized dealer must first authorize all warranty repairs.**

No warranty on this machine will be honored by Resurface Corp. other than that stated above.



## TABLE OF CONTENTS

### **For Safe Operation**

The OLYMPIA™ Battery Edger is intended for use, only by people who have a basic knowledge of motorized equipment operation and maintenance. Resurface Corp. cannot accept responsibility for any accidents that occur as a result of operation or maintenance of the machine .

Operating conditions vary widely and Resurface Corp. cannot predict these varying conditions, and it is therefore the user's responsibility to determine the appropriate settings in the operation of the OLYMPIA™ Battery Edger.

Each OLYMPIA™ Battery Edger is shipped with a variety of built-in safety devices. To prevent the occurrence of such accidents, all operators and maintenance personnel that deal with the machine must carefully read the manuals supplied by Resurface Corp., Guest® and Briggs & Stratton Etek™, before attempting to operate and maintain the OLYMPIA Battery Edger.

Because there are many "things that cannot be done" and "things that must not be done" when using the OLYMPIA™ Battery Edger, it is impossible to cover it all in the OLYMPIA™ Battery Edger manual. Assume that something is impossible or unsuitable unless the manual specifically states that it can be done.

The following manual is customized for the OLYMPIA™ Battery Edger. It provides detailed information regarding the following:

1 - DELIVERY PROCEDURE	
GUEST Charger Installation Procedure.....	1
2 - OPERATING PROCEDURE	
Battery Charging Procedure.....	3
Blade Inspection and Replacement Procedures .....	4
Edger Operational Procedure .....	6
Maintenance Program .....	6
Charger Safety Procedure .....	7
3 - PARTS LIST .....	8

**Please make use of this material when operating and maintaining the OLYMPIA™ Battery Edger. Fundamental safety information is high lighted throughout the manual.**

All cautions on operation must be strictly observed when operating the machine, carrying out maintenance work, and storing the equipment. Failure to observe the fundamental safety information can cause accidents in which the operator or other personnel that deal with the OLYMPIA™ Battery Edger are seriously injured, or the machine is damaged. All personnel that deal with the machine must carefully read and thoroughly understand the information in the following pages before attempting to operate or maintain the OLYMPIA™ Battery Edger.

### **Delivery Procedure**

**The OLYMPIA™ Battery Edger arrives fully assembled except for the blade tips. They are attached to ther handle in a plastic bag. Using the Blade replacement procedure on page 4 install the blade tips onto blade plate.**



## Delivery Parts Check

The OLYMPIA™ Battery Edger is delivered fully assembled along with the Guest® Model 2621 3 Output, 3 Stage battery charger.

Upon receipt of the OLYMPIA™ Battery Edger, install the charger in an open area, adjacent to a direct electric power source outlet, according to the Guest installation instructions for battery chargers.

**Safety Note: Make sure the charger is mounted in an open area, with the fins vertical to maximize venting of the internal heat.**

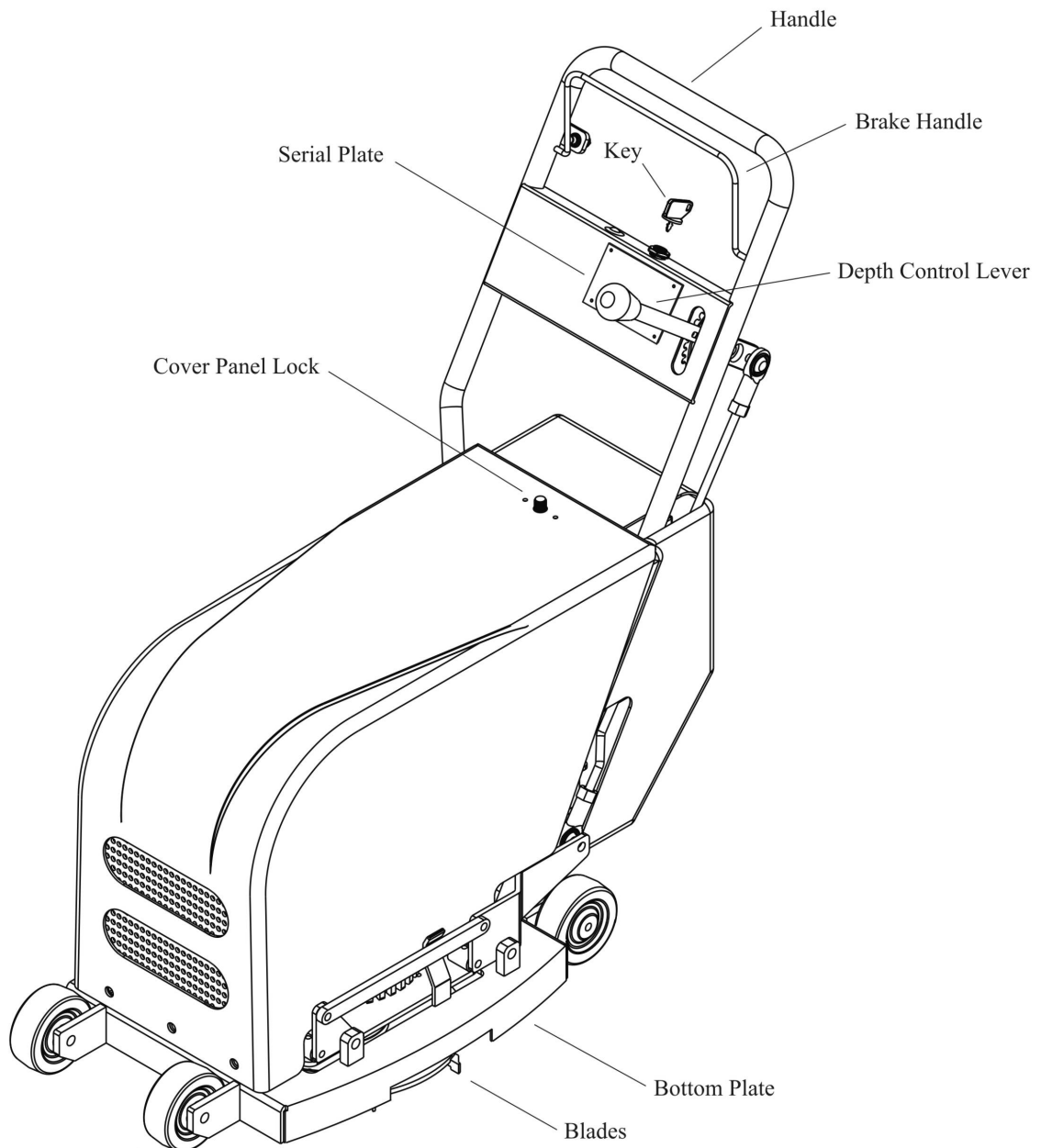



## **GUEST® 2621 Installation**

In order to optimize the performance and useful life of your charger, the following guideline for installation should be followed.

1. Chargers are electronic products designed for efficient energy conversion, specifically taking unregulated AC line power and converting it to an isolated low voltage DC power source. The nature of the process dictates that some heat is generated in the process, and consideration should be given to the proper dissipation of this heat. Electronic assemblies are sensitive to excessive heat and extreme temperatures could shorten the life cycle of the charger.
2. The measure of the output of a charger is called "watts", which are calculated by multiplying voltage X current. For example, a 12 volt, 10 amp charger will generate approximately 120 watts (12 X 10). If the "waste heat" generated by the charger was 10% of the rated wattage, it would be the equivalent of a 12 watt light bulb. In open air spaces, this heat is not an issue- but in a small box, it could get very hot.
3. Guest® chargers are cooled by convection. This means that as the charger generates warm air, it rises and cooling air takes its place. The efficiency of Guest® chargers allows them to build a product that does not require a fan running constantly over the electronic components. It is important that the charger is mounted in an area that will allow sufficient airflow. Keep in mind that the Guest® chargers will self-protect in extreme temperature by cutting back on the amperage output. Correct installation will ensure maximum efficiency.

There are a variety of configurations and cases available from Guest®. The following holds true for all models.

a) Always mount the charger with the fins vertical, so they can form a little chimney or air column to take away the internal heat. Remember, heat will affect the efficiency and longevity of your charger.

b) Guest® recommends that you do not mount the charger with the cooling fins horizontal.

c) Keep the top charger surface at least 4" below the ceiling of any compartment and the bottom of the charger surface at least 6" above the floor so the air can find its way around the body to provide cooling.

A backing or mounting panel of wood, metal, or heavy plastic should be used if the chargers are mounted against an insulated bulkhead.

4. Mounting Space: The larger the space, the greater the cooling. Use larger areas when available.



## Battery Charging Procedure

The OLYMPIA™ Battery Edger is re-charged by a Guest® Model 2621 "smart" charger. It first evaluates the amount of charge in each of the three batteries on the OLYMPIA™ Battery Edger. One of the batteries is charged at a rate of 10 amps and the other two are charged at a rate of 5 amps. Consequently one battery will charge faster than the other two. When the proper charge levels are obtained the battery charge cycle switches automatically into the trickle charge mode which maintains the battery at the peak charge.

The OLYMPIA™ Battery Edger three stage battery array is designed for safety and all operators must comply with the following safe battery charging instructions:

Step 1: Make sure the GUEST charger is unplugged from the main electric power source or the power control switch is turned off.

Step 2: Remove the ignition key from the OLYMPIA™ Battery Edger.

Step 3: Plug the charger into the OLYMPIA™ Battery Edger and then plug the charger into the direct electric power source.

**SAFETY NOTE: Always plug the charger into the OLYMPIA™ Battery Edger before plugging the charger into the direct electric power source.**

## Preparing to Charge Precautions

### Over Load Protection:

If an electrical short or overload (excessive demand) occurs in the DC wiring connected to this charger, the charger will reduce its output voltage to avoid damage. The GUEST Model 2621 has internal electronic current limiting. When an electrical short occurs, the red LED on the front panel will be on. The overload or short must be removed in order for the charger to start charging again. The chart below describes how the two sets of LED lights on the charger indicate the state of charge on your batteries.

DISPLAY	OPERATING CONDITION
Red lit Green unlit	When the red light is on, it indicates that the batteries are discharged and the charger is operating in the BULK mode (Stage 1) This charging rate is 10 amps and two 5 amps for each Engine start output.
Red lit Green lit	When both the green and the red lights are on, the charger is in ABSORPTION mode at between 9 and 3 amps (stage 2). This mode of charging gradually tops off the batteries, and reduces harmful sulfating. While both lights are on, the voltage measured (with the charger on) should be approximately 14 volts. If both lights stay on longer than 48 hours, refer to the trouble shooting page at the back of the GUEST manual.
Red lit Green unlit	When the green light is on, the charge is in its FLOAT mode at a current of less than 2 amps, (stage 3). Your battery is now 90% charged and ready for use. This float charging current will gradually decrease to as low as 0.1 amp over the next day as the battery reached 100% charge. The batteries will now be kept at full charge without over-charging. The battery voltage is maintained at 13.3 VDC. If the green light stays on when you battery is known to be low, refer to the trouble shooting in the Guest manual.

**Maintaining the OLYMPIA™ Battery Edger: Periodically clean all the battery terminals with baking soda and tighten all connections. No other maintenance is required.**

## Battery Cycles

The sealed lead acid gel batteries on the OLYMPIA™ Battery Edger are rated for 1,600 cycles. Every time the OLYMPIA™ Battery Edger is plugged into the GUEST charger constitutes a single cycle. A full charge on the batteries provides for approximately 40 to 60 minutes of operating time, depending on how deep a cut you are making. If you edge the ice surface once a day, it should only take 15 minutes to complete the edging procedure. Consequently, to get maximum life out of the batteries you should recharge the batteries every third or fourth day.

**SAFETY NOTE: When your are ready to edge the ice, make sure you disconnect the direct electric power source to the charger and then disconnect the charger from the OLYMPIA™ Battery Edger.**

## Blade Installation

Before using the OLYMPIA™ Battery Edger you first must inspect the blades to ensure they are undamaged and secured tightly to the blade plate.

**SAFETY NOTE: Prior to inspecting the blade tips make sure you are wearing protective gloves.**

1. To check the blades: first remove the ignition key.
2. Now tilt the OLYMPIA™ Battery Edger backward onto the sloped back. Unlike other edgers on the market the OLYMPIA™ Battery Edger's batteries are gel filled and sealed, allowing you to lay it over at any angle. However, the OLYMPIA™ Battery Edger is designed to safely support the unit when the control handle is pushed downward, tilting the unit onto its sloped back.
3. Rotate the blade plate and visually inspect each of the blade tips to ensure they are undamaged, sharp and securely tighten to the blade plate. If the blade tip is damaged, the OLYMPIA™ Battery Edger will vibrate and you will get an uneven finish on the ice. Even more important, a loose or damaged blade tip could separate from the blade plate and cause serious injury or damage.

**Safety Note: Most blade damage is caused by hitting screws in the dasher boards or ice surface entrance thresholds.**

4. When a blade needs replacement, first undo the four bolts holding the blade plate in place.
  5. On a work surface loosen the two bolts holding the blade tip to the blade plate. Remove the damaged tip and replace it with a new blade tip, making sure to position it correctly on the plate before tightening the holding bolts to a maximum 11 ft. lbs of torque.
  6. Using a straight edge along the opening in the cutting side of the edger, adjust the blade tips in or out along the slotted guides until they are 1/16 to 1/8 of an inch (1.6 mm to 3.2 mm) from the straight edge. Hand tighten and check clearance.
- Positioning the blade tip beyond the blade guard casing will cause damage to both the blade tip and the boards.

To maintain the consistent edging, make sure the blade tips are the same distance from the outer edge of the blade guard casing.

To double check, measure an existing undamaged blade for the proper measurement and adjust the new blade accordingly.

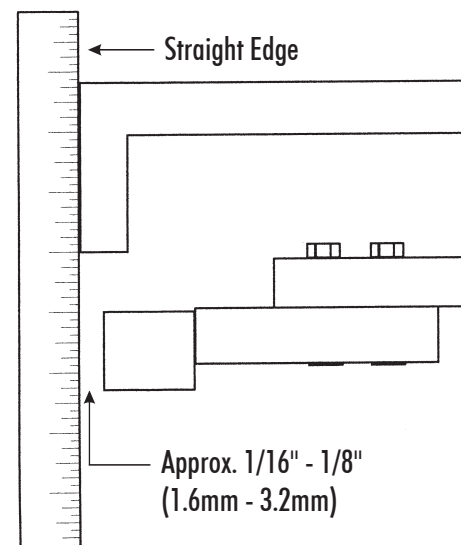



7. On the eight blade plate, we recommend every second blade be inset by moving it to the back of the slide groove. The alternate blade tips are positioned correctly by measuring from the outer edge of the blade guard casing to the tip of the blade. It should be 1/16" to 1/8" inside the edge.

When the blades are inspected and replaced if necessary, re-attach the blade plate with the four bolts making sure to tighten to a maximum 11 ft. lbs. of torque on the grade 8 bolts.

**Safety Note: Make sure you do not over torque the blade attachment bolts. It can cause the blade to break and fly out from under the edger. Because of the high velocity of the spinning blade plate this can be extremely dangerous.**

## Edging Procedure

Once the OLYMPIA™ Battery Edger is charged, the blades inspected and replaced if necessary, you are ready to edge the ice surface.

**Safety first: Before entering the ice surface make sure you are wearing steel toed boots, safety goggles or glasses, and studded slip on boot covers to provide proper traction on the ice.**

The OLYMPIA™ Battery Edger is designed to remove ice build up along the boards and level the ice surface. Ice buildup extends from the board into the ice surface. To properly level the ice we recommend the following procedure:

1. Push the OLYMPIA™ Battery Edger onto the ice surface. Securely close the entrance door and ensure that all the other entrance doors are closed and secured.
2. Walk the entire circumference of the ice surface examining the board surfaces for protruding screws and materials embedded into the ice and/or boards. Remove any such debris. This will prevent damage to the edger, the boards and most importantly to the operator.
3. After completing the board inspection walk around the circumference of the rink a second time, examining the ice surface for high spots. Using a felt tip pen, mark the beginning of a high spot with a line and an arrow pointing forward along the high spot. At the end of the high spot mark another line and an arrow pointing backwards. This will clearly indicate where you have to spot edge the ice.
4. With the blades in the fully up position turn on the OLYMPIA™ Battery Edger compress the start bar on the handle and push the edger forward to the first marked high spot.

**It is very important to keep the edger moving throughout the edging process.**

5. When the edger is against the board and you reach the first arrow, lower the cutting blades by pushing the lock button on the blade height control lever to release it and lower the cutter assembly by pushing the lever downward. The blades will begin to cut into the high spot, removing the ice. As you reach the end of the high spot, push in the control button on top of the blade height lever and pull up to bring the blades off the ice surface. Repeat this until each high spot has been removed.

6. Once the high spots are removed do a second lap around the ice circumference. Move the edger against the boards with the blades spinning in the raised position. Now moving forward push the blade height control lever until the cutter assembly starts cutting a thin cut of the ice. Maintaining that cut level, edge the entire circumference of the ice surface.

**SAFETY NOTE: NEVER move the OLYMPIA™ Battery Edger backward when the blades are moving or try to cut backwards.**

7. When you have completed a full circuit around the ice, raise the cutter assembly to the full up position, release the start bar and turn off the key. Exit the ice surface and store the OLYMPIA™ Battery Edger in the proper storage area next to the charger.

**SAFETY NOTE: Always release the safety bar before turning the ignition key off. Turning key off while the safety bar is engaged can cause severe damage to the OLYMPIA™ Battery Edger .**

A fully charged OLYMPIA™ Battery Edger is able to complete three to four full edging procedures under normal ice build up scenarios following a daily edging regime.

The Briggs & Stratton Etek™ motor on the OLYMPIA™ Battery Edger, has a safety preset which turns off the motor if it is over worked or over heats. If this occurs, simply turn the ignition key to the off position and wait until the motor has had time to cool down. Once cooled the Briggs & Stratton Etek™ can be started following the normal starting procedure.

**Electric Motor Safety Feature** **SAFETY NOTE: When doing any inspection or maintenance work on the OLYMPIA™ Battery Edger always remove the ignition key first. This is the best safety measure you can use in preventing accidents.**

To open the OLYMPIA™ Battery Edger turn the opening knob on the top of the edger casing counter-clockwise. You will note the three batteries which are pre-wired together and enclosed in a safety harness.

Each battery has it's own fuse leading from the charging circuit through the conduit wire harness.

**Maintenance Procedure** **DANGER: The 100 amp fuse located at the front of the OLYMPIA™ Battery Edger, is hot. Do not touch. Whenever working on the OLYMPIA™ Battery Edger, make sure you are not wearing any rings, bracelets or watches which can cause an electric arc and severe injury.**

If you have to remove the 100 amp fuse make sure the battery array is disconnected by disengaging the positive terminal (red wire) from the front battery before touching the 100 amp fuse. Do not re-engage the positive terminal until after you have replaced the 100 amp fuse.

**Risk of explosive gases! Working in the vicinity of sealed lead acid gel batteries is dangerous. Batteries generate explosive gases during normal operation. Therefore it is of utmost importance you follow these instructions exactly.**



**IMPORTANT  
CHARGER  
SAFETY  
INSTRUCTIONS**

Adhere to the following personal safety precautions when installing or working with the chargers.

1. Someone should be within voice range or close enough to come to your aid when you work near a seal lead-acid Gel battery.
2. Have plenty of fresh water and soap nearby in case battery acid contacts your skin, clothing or eyes.
3. Wear complete eye protection and clothing protection. Avoid touching your eyes while working near a battery.
4. If battery acid contacts your skin or clothing, wash them immediately with soap and water. If acid enters your eye, flood the eye with cold, running water for at least ten minutes and get medical attention.
5. Never smoke or allow open flame in the vicinity of the battery.
6. Do not drop a metal tool onto the battery. It may spark, short circuit the battery and may cause an explosion.
7. Remove all personal metal items such as rings, bracelets, necklaces and watches when working near a lead-acid battery. A battery can produce short circuit currents high enough to weld a ring or the like, causing a severe burn.

**SAFETY NOTE: If after charging you find the performance power is low have the batteries checked by a qualified battery technician.**

**Always make sure the ice is clear of both members of the public and arena staff prior to operating the edger.**

**Safety Glasses, (steel toed) safety boots with proper grips must be worn by all staff during edging operation.**



## Control Arm

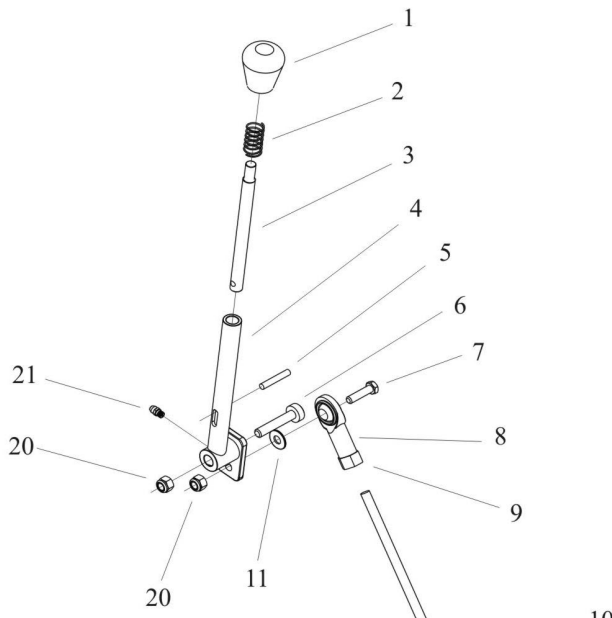

Ref.#	Part #	Description	OEM #
1	55- 5120	Depth Selector Handle Knob	
2	10- 120	Gear Shift Spring	C18291600318
3	55- 5100	Depth Selector Rod	
4	55- 5110	Depth Selector Handle Knob	
5	49-37800	Split Pin 1/4 x 1 1/2	
6	50-51925	Axle 1/2 x 1 1/4	1/2 x 1 1/4 Stripper Bolt
7	49-30550	Hex Hd bolt 3/8 x 1 1/4	3/8 - 16 x 1 1/4
8	25-51855	Rod End	VCW6
9	49-33600	Hex Hd Nut 3/8-24	
10	55-25330	Depth Adjustment Rod	
11	49-36250	Flat Washer 3/8	
12	49-33235	Hex Hd Jam Nut 5/16-18	
13	49-30050	Stripper Bolt 3/8 x 3/8	
14	55- 3210	Engine Mount Connecting Bar	
15	49-33555	Hex Jam Nut 3/8-16	
16	49-19025	Grease Fit 1/4-28 45 Deg.	1636
17	55- 3150	Front Engine Mount Depth Adj.	
18	55-25310	Engine Mount	
19	55- 3200	Back Engine Mount Depth Adj.	
20	49-33500	Locknut-Nylon 3/8-16	
21	49-19035	Grease Fitting 1/4-28 Straight	

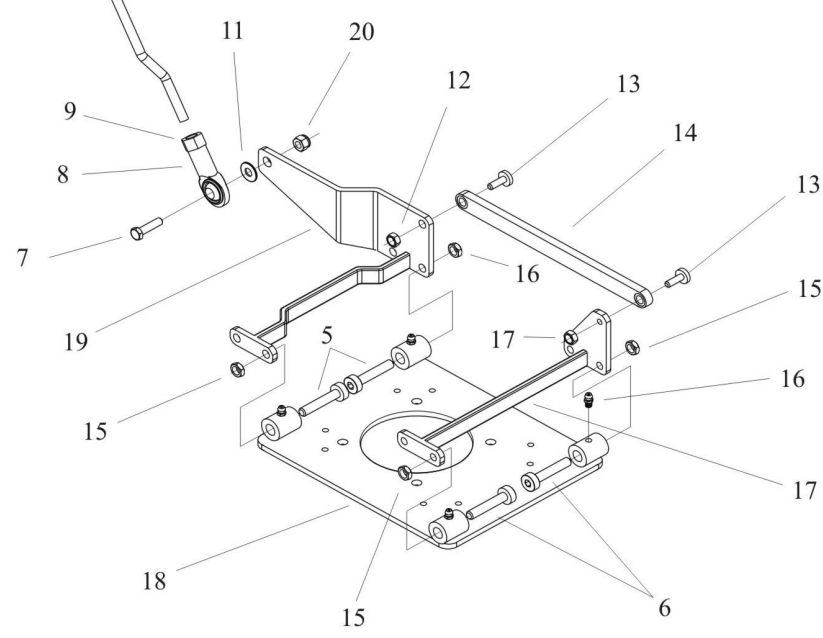



## Handel Bar

Ref. #	Part #	Description	OEM #
1	55-25450	ON/OFF Bar	
2	55-25400	Handle	
3	49-30500	Hex Hd Bolt 3/8 x 1	3/8 - 16 x 1
4	49-33555	3/8 - 16 Hexjam Nut	
5	55- 1050	Motor Mount Pivot Bolt	1/2 x 1/2 Stripper Bolt
6	49-33200	Locknut Nylon 1/4-20	
7	35-23860	Bottom Hub Washer	
8	55-25070	Safety Push Button	OTT P1-62122
9	50-53015	Valve Pilot Light	PL-20-GC 2 Wire
10	49-30230	Hex Hd Bolt 1/4 x 1	1/4-20 x 1
11	55-25042	Controller Mount	
12	55-25040	Motor Controller	SRE-MC 248-11
13	49-30200	Hex Hd Cap Screw 1/4 x 3/4	1/4-20 x 3/4
14	49-36100	Flat Washer 1/4 Hole	3/16 Flat Washer - Zinc
15	50-53250	Key Switch	95614
16	49-33500	Locknut -Nylon 3/8-16	

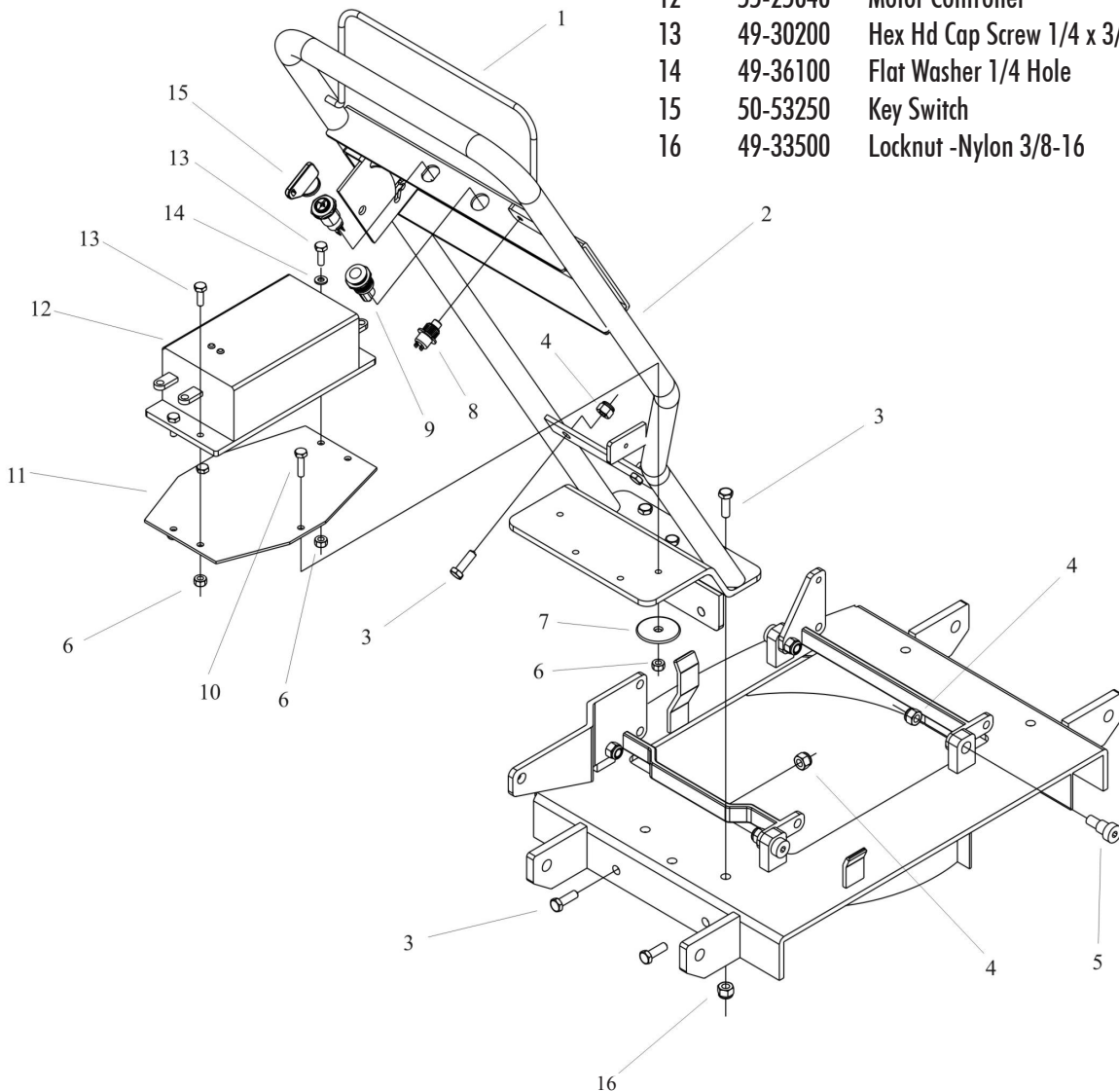

**Panels & Sled**

Ref.#	Part #	Description	OEM #
1	49-33130	Locknut-Nylon 10-32 S/S	NS11S1
2	46- 9600	Panel Turn Latch	MO99957-10-201-10 Spring Latch
3	49-30134	Button Hd Soc10-32x1/2 S/S	
4	49-36045	Nylon Flat Washer # 10	WF194375032NY.194x.375x.032
5	55-25010	Edger Battery Cover Front	
6	49-36140	Nylon Flat Washer 1/4	WF257500032NY.257X.500X.032
7	49-30233	Button Hd Soc 1/4-20x1 S/S	CSB 1416S1
8	49-30550	Hex Hd Bolt 3/8x1 1/4	3/8-16x1 1/4
9	55-25015	Edger Battery Front Hood Hinge	
10	49-33213	Well Nut 1/4-20	NWEL1418
11	49-33500	Locknut-Nylon 3/8-16	
12	49-33075	Well Nut 10-32	NWEL111910-32x.015-.192
13	55-25085	Battery Connector Rec.70084	CPR70084
14	49-30135	Button Hd Soc 10-32x3/4 S/S	CSB1112S1
15	55-25020	Edger Battery Cover Back	

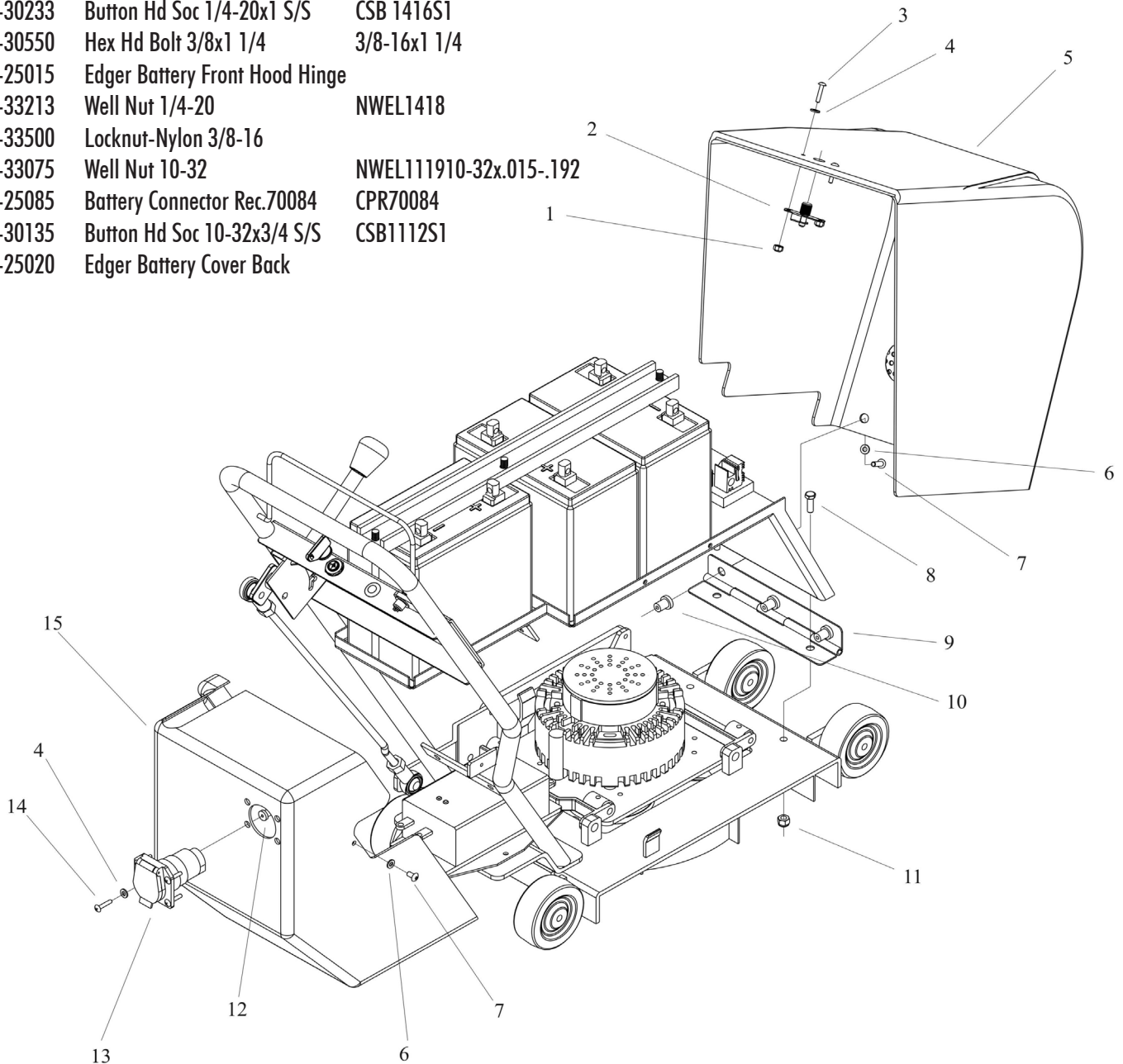

## Under Carriage

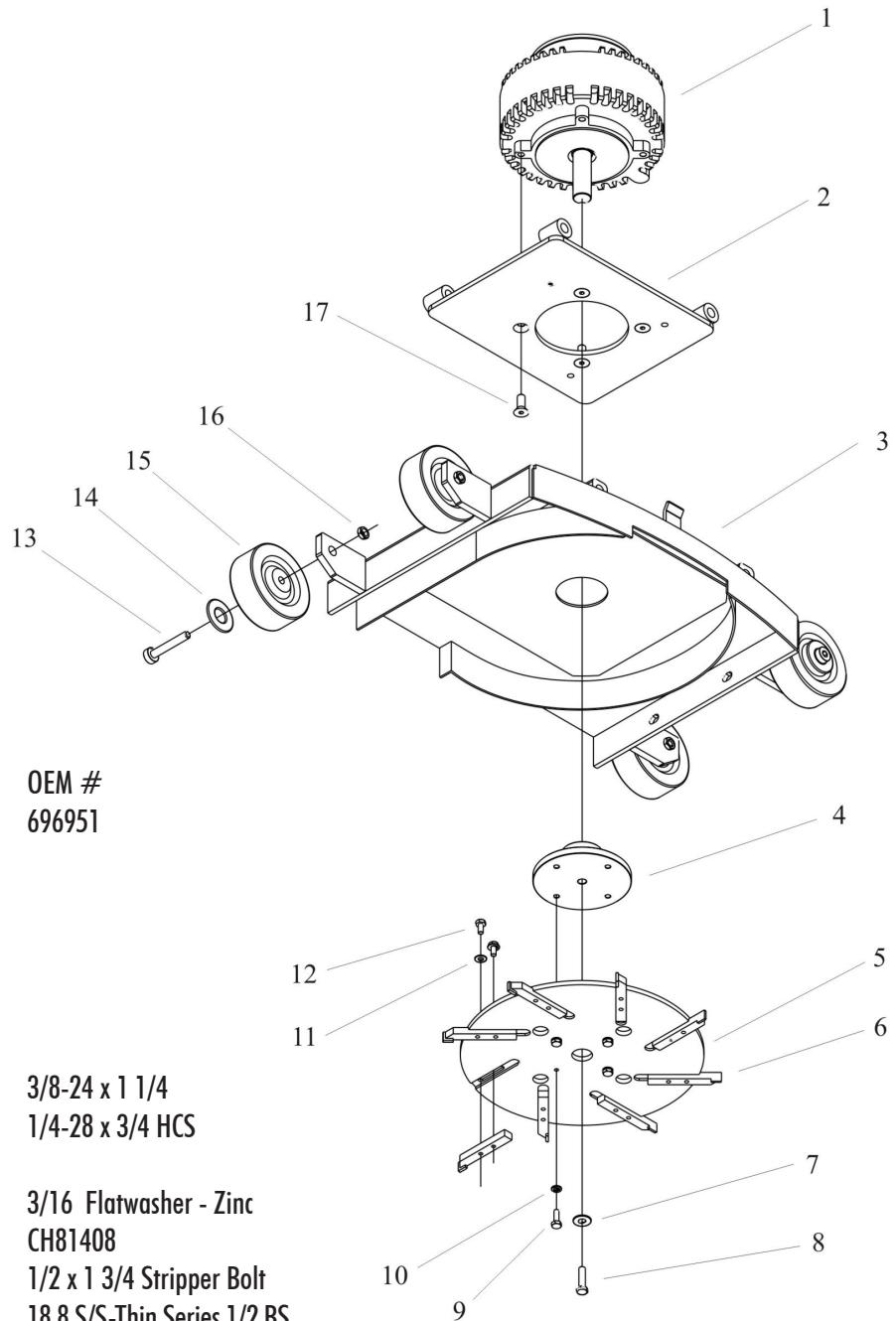

Ref. #	Part #	Description	OEM #
1	55-25005	Motor Electric	696951
2	55-25310	Engine Mount	
3	55-25300	Base	
4	55-25350	Bottom Hub	
5	55-25355	Bottom Plate	
6	50-51760	Edger Blade	
7	49-36250	Flat Washer 3/8	
8	49-30560	Hex Hd bolt 3/8 x 1 1/4	3/8-24 x 1 1/4
9	49-30205	Hex Hd Bolt 1/4 x 3/4	1/4-28 x 3/4 HCS
10	49-36170	Lockwasher 1/4	
11	49-36100	Flat Washer 1/4 Hole	3/16 Flatwasher - Zinc
12	49-30152	Hex Head Bolt 1/4 X 1/2 GR8	CH81408
13	50-51930	Back Axle	1/2 x 1 3/4 Stripper Bolt
14	55- 1010	Wheel Washer	18.8 S/S-Thin Series 1/2 BS
15	55- 1000	Rubber Wheel 4"	RED 100PU14
16	49-33555	3/8 - 16 Hexjam Nut	
17	49-30530	Flat Socket Screw 3/8 x 1	3/8-16x1

# 3

## PARTS LIST

### Battery Tray

Ref. #	Part #	Description	OEM #
1	49-33500	Locknut - Nylon 3/8 - 16	
2	49-36250	Flat Washer 3/8	
3	55-25095	Battery Hold Down Channel 22"	R-13858
4	55-25000	Edger Battery	SLA12-55
5	55-25045	Edger Battery Relay-Contactor	SRE-CT-SW80B-60
6	49-30110	RD Soc. M/S 10/24 x 1/2	
7	55-25055	Edger Battery 100 Amp Fuse	LJP-100SP
8	55-25050	Edger Battery Fuse Block 100A	LJ60100-1C
9	49-33115	Locknut-Nylon 10-24	10-24 Nylon Insert Locknut
10	55-25100	Edger Battery Tray	
11	49-30550	Hex Hd Bolt 3/8 x 1 1/4	3/8-16x 1 1/4
12	49-38290	M4 x 8 Hex Cap Screw	9338M0408
13	37- 198	Insulated 3/8 " Clamp	35030
14	49-30150	Hex Hd Bolt 1/4 x 1/2	1/4-20 x 1/2
15	49-33200	Locknut - Nylon 1/4 - 20	

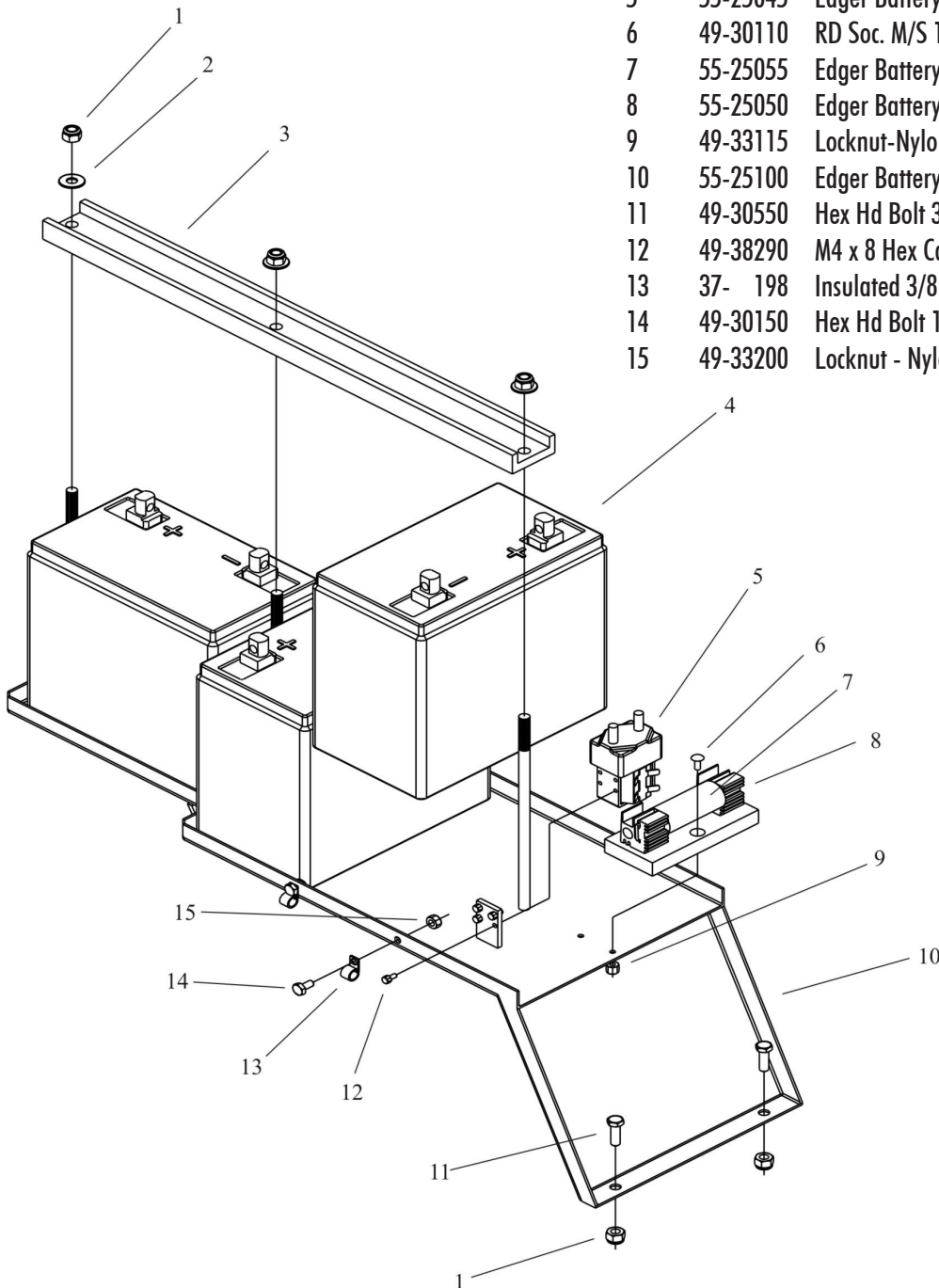

## Electrical System

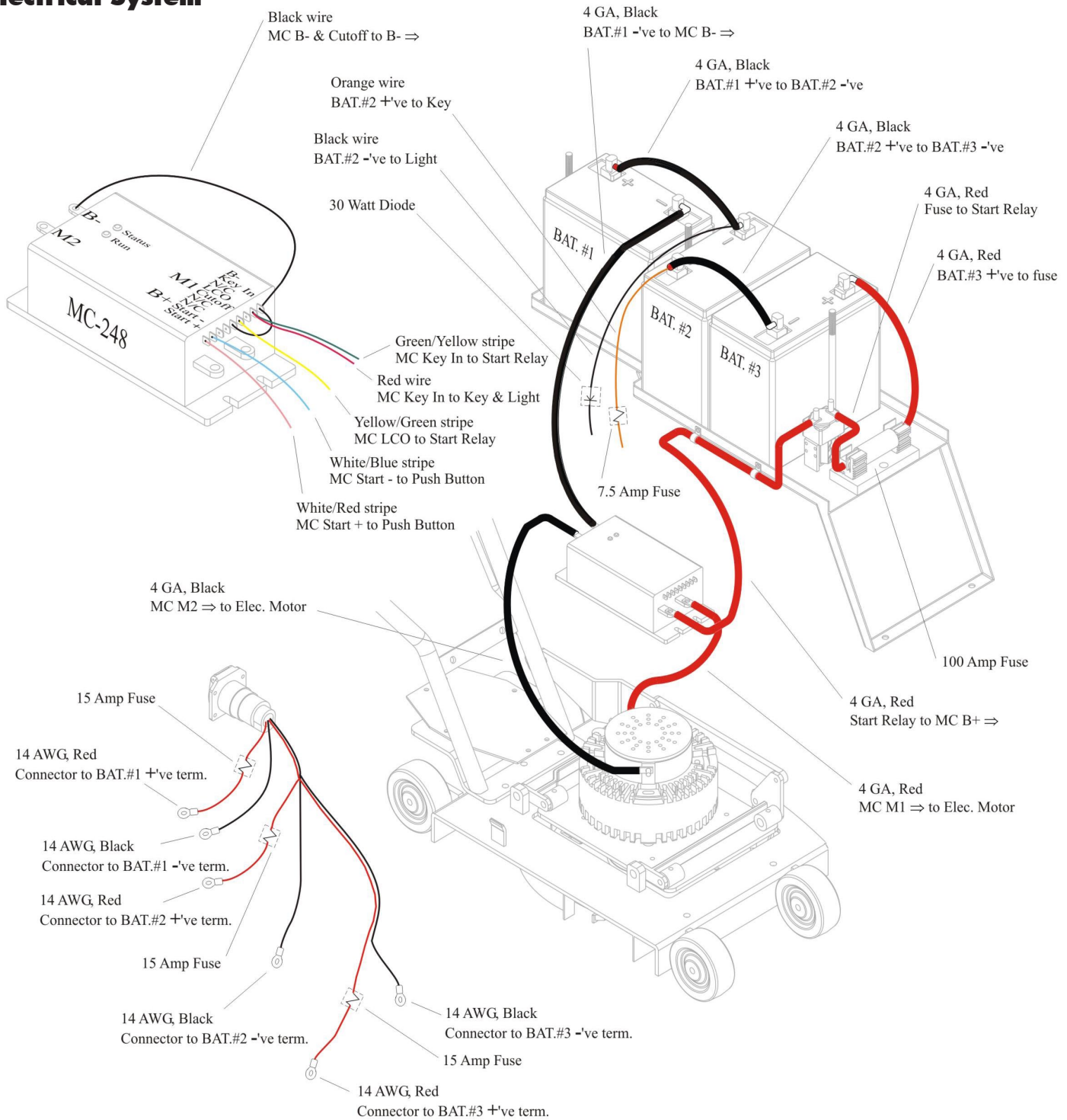

**NOTE:**

- RED WIRES ALWAYS +VE
- BLACK WIRES ALWAYS -VE

**WARNING :** INSTALLING BACKWARDS WILL CAUSE DAMAGE AND POSSIBLE INJURY.

